

Competition, Imitation and Growth with Step-by-Step Innovation

Philippe Aghion
Harvard University, University College London and CEPR

Christopher Harris
Faculty of Economics and King's College, Cambridge

Peter Howitt
Brown University

and

John Vickers
All Souls College, Oxford

October 2000

Abstract

Is more intense product market competition and imitation good or bad for growth? This question is addressed in the context of an endogenous growth model with “step-by-step” innovations, in which technological laggards must first catch up with the leading-edge technology before battling for technological leadership in the future. In contrast to earlier Schumpeterian models in which innovations are always made by outsider firms who earn no rents if they fail to innovate and become monopolies if they do innovate, here we find: first, that the usual Schumpeterian effect of more intense product market competition (PMC) is almost always outweighed by the increased incentive for firms to innovate in order to escape competition, so that PMC has a *positive* effect on growth; second, that a little imitation is almost always growth-enhancing, as it promotes more frequent neck-and-neck competition, but too much imitation is unambiguously growth-reducing. The model thus points to complementary roles for competition (anti-trust) policy and patent policy.

We thank, without wishing to implicate, Jan Boone, Amy Glass, Pravin Krishna, Jim Peck, Steve Redding, John Van Reenen, two anonymous referees, and seminar participants at Tel-Aviv, Harvard, Rochester, Brown, Ohio State and Jerusalem, for helpful comments on earlier drafts.

1 Introduction

Is more intense competition good or bad for innovation and growth? The Schumpeterian branch of endogenous growth theory has generally addressed these questions by focusing on the monopoly rents that accrue to a successful innovator. Thus, by reducing the flow of rents, more product market competition (PMC) should reduce incentives for innovation and growth (for example, see Aghion and Howitt, 1992 or Caballero and Jaffe, 1993).¹ Similarly, easier imitation and weaker patent protection should diminish R&D incentives by reducing the expected duration of rents from innovation (see Zeng, 1993 or Davidson and Segerstrom, 1998).²

Of course, the incentive to perform R&D depends not on the rents of a successful innovator *per se*, but rather on the innovator's *incremental* rents; that is, the difference between the rents of a successful innovator and an unsuccessful one. This distinction does not arise in most Schumpeterian models, in which innovations are made by outsider firms who earn no rents if they don't innovate, and who become local monopolists if they do. An incumbent monopolist does not innovate in these models because of the Arrow (replacement) effect; since it is already enjoying monopoly rents it has a weaker incentive than outsiders, so that if the R&D technology exhibits constant returns to scale and the incumbent has no R&D advantage, it will choose not to perform R&D in equilibrium (see Aghion and Howitt, 1992). A new innovator becomes a monopolist in its own industry because of the (implicit) assumption of *undifferentiated* Bertrand competition within each innovative sector.

In reality, however, most innovative activity occurs within industries com-

¹One exception is Peretto (1999), which we discuss later in this section.

²Segerstrom (1991) found that a subsidy to imitation could raise growth, but Davidson and Segerstrom show that the equilibrium analyzed in that model is unstable and not unique. Also, the conventional wisdom with respect to imitation is not generally borne out by product-cycle models in which imitation takes place in low-wage countries (the South) while innovation takes place in the North. (Grossman and Helpman, 1991, Helpman, 1993, Glass, 1999, Glass and Saggi, 1999). We do not deal with the open-economy mechanisms involved in these papers.

prising more than one firm, and within existing firms that are already earning rents. Thus the rents of a successful innovator may be a poor indicator of the incentive to innovate. For example, more PMC might reduce a firm's pre-innovation rents by more than it reduces post-innovation rents. Indeed, this is what one would expect as a result of the "selection effect"³ of market competition; that is, a more competitive industry is one in which the profits earned by the industry's technology leader are larger relative to other firms in the industry. Thus an increase in PMC can stimulate R&D by increasing the incremental profit from innovating, that is, by strengthening the motive to innovate in order to *escape* competition with "neck-and-neck" rivals, even though it may reduce the industry's overall level of absolute profits. If this motive is important it would help reconcile the Schumpeterian paradigm with recent empirical work (e.g. by Nickell, 1996 or Blundell et al., 1995) pointing to the possibility of a *positive* correlation between PMC and productivity growth within a firm or industry.⁴

Also, a firm that is imitated may face a larger incentive to innovate than before, even though its prospective rents from an innovation are lower than before, because it is now in neck-and-neck competition with a technologically equal rival and will remain so until it innovates again. So, for example, even if a relaxation of patent protection reduces the R&D effort of a firm with any given lead size it might still raise the economy's growth rate by forcing more firms into the neck-and-neck situation in which they are induced to spend the most on R&D. More generally, anti-trust policy (which directly affects PMC) and patent legislation (which affects the ease of imitation) affect growth not only through their direct effect on innovation incentives in each individual industry but also through their "composition effect," that is, through their influence on the cross-industry distribution of technological gaps and the

³The term "market selection" originates with Vickers (1995). See also Boone (1999) and Aghion and Schankerman (2000) for applications of this notion to the economics of innovation.

⁴This "escape competition" motive has been pointed out in previous theoretical work on innovation, for example by Mookherjee and Ray (1991) in the context of a one-sector model in which a dominant firm adopts new innovations at discrete moments in time, and where the newest technology diffuses at an exogenous rate to a competitive fringe; in this paper, an increase in the rate of diffusion may sometimes speed up innovations by the dominant firm by strengthening the motive to escape from the fringe.

corresponding distribution of incremental rents, and in particular on the frequency of a zero gap.

The purpose of this paper is to reconsider the question posed at the outset, by addressing it in a framework where innovations are undertaken by incumbent firms, where the above mentioned “escape competition” motive for R&D is operative, and where composition effects are at work. Specifically, we portray technological progress as emerging from a dynamic process of “step-by-step” innovation, along the lines of Harris and Vickers (1987) and Budd et al. (1993): first, instead of monopolistic competition we assume that each industry is characterized by duopoly; second, because firms face a rising marginal cost of R&D, therefore R&D will be conducted simultaneously by both incumbent firms in an industry; third, a technological laggard in any industry cannot leap-frog the existing leader in that same industry: it must first catch up with the current leader before racing for technological leadership in the future. This, in turn, implies that in a positive fraction of industries competition will be neck and neck and therefore the escape competition effect will be strong.

A precursor paper by Aghion et al. (1997) considered the effects of imitation and product market competition on growth, using the same basic framework as in this paper. However, the analysis in that paper was limited to the simple case where the technological gap between firms cannot exceed one step; furthermore, when discussing the impact of product market competition on growth, it focused on the comparison between Cournot and Bertrand competition. The present paper extends the analysis in Aghion et al. (1997), first by not imposing any kind of restriction on the size of technological gaps across industries, i.e on the set of possible industry structures, and second by using a continuous parametrization (in terms of the substitutability between duopolistic products within each industry) to measure the degree of product market competition (PMC). We thus derive more precise results and predictions regarding the effects of PMC and imitation on the long-run industry structure (as measured by the distribution of technological gaps in steady-state equilibrium) and the long-run average growth rate.

Our paper is related to other papers in the Schumpeterian growth litera-

ture that allow innovations by incumbent producers. Barro and Sala-i-Martin (1995, ch.7) and Segerstrom and Zolnierrek (1999) allow incumbents to have a cost advantage over outside firms, but do not examine the effects of PMC on growth. Thompson and Waldo (1994) and Aghion et al. (1999) present models of monopolistic competition with no entry, in which PMC has the usual Schumpeterian effect unless additional assumptions are introduced into the framework. Thompson and Waldo make an assumption about the size of inter-industry spillovers guaranteeing that all firms have the same incentive to innovate regardless of their technological lead or lag over other firms. In the model of Aghion et al., all innovations are done by firms that are furthest behind the technological frontier, and whose situation is therefore much like that of an outsider; yet, whenever innovating firms face agency problems, PMC can become growth-enhancing by forcing otherwise reluctant managers to innovate in order to avoid costly bankruptcy.

Peretto (1999) presents a model of monopolistic competition with a deterministic R&D technology that produces a continuous stream of cost-reducing innovations at the firm level, and finds that PMC has a positive effect on the equilibrium level of innovation. In this model, unlike other Schumpeterian models, R&D involves no spillovers, so that growth depends on R&D per firm rather than aggregate R&D. An increase in PMC raises growth by reducing an entrant's prospective rents, which reduces the equilibrium number of firms, which thus leads to more R&D per firm and hence more growth. Also, since all firms are symmetric at all times, there are no composition effects at work.

Our paper also differs from all of the above papers in that it portrays each industry as being duopolistic, rather than assuming monopolistic competition. Thus we can examine the effects of competition *within* each industry, which is the focus of all anti-trust policy, rather than competition between industries, which is all that one can consider with monopolistic competition. Moreover, none of these other papers examines the effect of imitation on growth.

Our findings can be summarized as follows. With respect to PMC, we find that at least a little competition is always growth-enhancing. That is,

starting from the minimal degree of PMC and holding constant the ease of imitation, a marginal increase in PMC always raises the growth rate. For most parameter values this positive *ceteris paribus* effect of competition on growth continues to hold as the degree of PMC rises to its maximal level (at which there is perfect competition). When we allow both PMC and imitation to be varied together we find that the maximal growth rate is *always* achieved by allowing the maximal degree of competition. Thus it seems that the usual Schumpeterian effect of more intense competition is almost always outweighed by the increased incentive for firms to innovate in order to escape competition.

With respect to imitation, we find that a lot of it is always bad for growth. That is, as the ease of imitation goes to infinity the growth rate always falls to zero. However, a little imitation is almost always growth-enhancing; holding constant the degree of competition, the marginal effect of raising the ease of imitation above zero is almost always to raise the growth rate. The only cases in which this does not hold are cases in which the degree of competition is close to maximal. Thus the usual Schumpeterian effect of imitation always prevails for large propensities, but is usually outweighed by the composition effect of promoting more frequent neck-and-neck rivalry when the propensity is not too large.

In short, our findings are that the effect of PMC on growth usually is monotonically positive, but sometimes is inverse-U shaped, whereas the effect of imitation on growth usually is inverse-U shaped but sometimes is monotonically negative.

The plan of the rest of the paper is as follows. The basic model is presented in section 2. It is similar to previous “quality ladder” models, but with step-by-step technological progress instead of the more commonly assumed leap-frogging, and with duopolies instead of monopolistic competition. We then proceed to analyse the economy’s steady-state growth rate in three stages, each corresponding to a different range of values of the parameter γ that represents the size of innovations. Section 3 analyses a two-state example that approximates the case in which innovations are very large; this example is simple enough to yield closed-form solutions. Section 4 studies

the case in which innovations are very small, using the method of asymptotic expansions around the point where $\gamma = 1$. Section 5 analyses the general model and presents numerical results for intermediate values of γ . Section 6 concludes by suggesting possible extensions.

2 Basic model

2.1 Consumers

Consider an economy with a continuum of industries indexed by $i \in [0, 1]$. There is a continuum (of total mass 1) of infinitely-lived consumers with identical intertemporal preferences:

$$U = \int_0^\infty \left\{ \int_0^1 \ln Q_i(t) di - L(t) \right\} e^{-rt} dt, \quad (1)$$

where $Q_i(t)$ denotes consumption at time t of industry i 's output, $L(t)$ is labor supplied and $r > 0$ is the rate of time preference.⁵

There are two firms in each industry i . Let q_{Ai} and q_{Bi} respectively denote the outputs of these two firms. Industry output is given by: $Q_i = f(q_{Ai}, q_{Bi})$ where $f(\cdot)$ is a symmetric function that is homogenous of degree one in its two arguments (and independent of i). Throughout the paper attention is restricted to the particular case in which:

$$f(q_{Ai}, q_{Bi}) \equiv (q_{Ai}^\alpha + q_{Bi}^\alpha)^{1/\alpha}, \quad \alpha \in (0, 1].$$

The parameter α measures the degree of substitutability between the two goods in any industry.

The log-preference assumption made in (1) implies that in equilibrium individuals spend the same amount on each basket Q_i . We normalize this

⁵This preference specification implies that labor supply is infinitely elastic. The case of inelastic labor supply is briefly analyzed by Aghion et al. (1997), who suggest that the resulting wage movements mitigate the effect of competition on growth. Specifically, more product market competition tends to increase the demand for both manufacturing workers and R&D workers: the demand for manufacturing workers within each industry should increase as this industry becomes more competitive and therefore produces more, and the demand for R&D workers should go up as a result of the increased incentive for neck-and-neck firms to escape competition. The resulting upward pressure on wages should reduce the incremental rents of innovators, and therefore reduce their incentive to innovate.

common amount to unity by using expenditure as the numeraire for the prices p_{Ai} and p_{Bi} at each date. Thus the representative household chooses each q_{Ai} and q_{Bi} to maximize $f(q_{Ai}, q_{Bi})$ subject to the budget constraint: $p_{Ai}q_{Ai} + p_{Bi}q_{Bi} = 1$, and the demand functions facing the two firms in industry i are:

$$q_{Ai} = \frac{p_{Ai}^{\frac{1}{\alpha-1}}}{p_{Ai}^{\frac{\alpha}{\alpha-1}} + p_{Bi}^{\frac{\alpha}{\alpha-1}}} \quad \text{and} \quad q_{Bi} = \frac{p_{Bi}^{\frac{1}{\alpha-1}}}{p_{Ai}^{\frac{\alpha}{\alpha-1}} + p_{Bi}^{\frac{\alpha}{\alpha-1}}}$$

2.2 Product-market competition

Each firm produces using labor as the only input, according to a constant-returns production function, and takes the wage rate as given. Thus the unit costs of production c_A and c_B of the two firms in an industry are independent of the quantities produced. Assume that the firms compete in prices, arriving at a Bertrand equilibrium. According to the above demand functions, the elasticity of demand faced by each firm j is $\eta_j = (1 - \alpha\lambda_j) / (1 - \alpha)$, where $\lambda_j = p_j q_j$ is the firm's revenue:

$$\lambda_j = \frac{p_j^{\frac{\alpha}{\alpha-1}}}{p_A^{\frac{\alpha}{\alpha-1}} + p_B^{\frac{\alpha}{\alpha-1}}}, \quad j = A, B \quad (2)$$

Thus each firm's equilibrium price is:

$$p_j = \frac{\eta_j}{\eta_j - 1} c_j = \frac{1 - \alpha\lambda_j}{\alpha(1 - \lambda_j)} c_j, \quad j = A, B \quad (3)$$

and its equilibrium profit is:

$$\Pi_j = \frac{\lambda_j}{\eta_j} = \frac{\lambda_j(1 - \alpha)}{1 - \alpha\lambda_j}, \quad j = A, B \quad (4)$$

Equations (2) ~ (4) can be solved for unique equilibrium revenues, prices and profits. Given the degree of substitutability α , the equilibrium profit of each firm j is determined by its relative cost $z = c_j/c_{-j}$; an equiproportional reduction in both c_A and c_B would induce each firm to reduce its price in the same proportion, which, because industry demand is unit-elastic, would leave the equilibrium revenues and profits unchanged. More formally, (2) ~ (4) implicitly define a function $\phi(z, \alpha)$ such that:

$$\Pi_A = \phi(c_A/c_B, \alpha) \quad \text{and} \quad \Pi_B = \phi(c_B/c_A, \alpha). \quad (5)$$

The substitutability parameter α is our measure of the degree of product market competition in each industry. Although α is ostensibly a taste parameter, we think of it as proxying the absence of institutional, legal and regulatory impediments to entering directly into a rival firm's market by offering a similar product. Under this interpretation α reflects in particular the influence of anti-trust policy.

In our model α corresponds to standard measures of competition. For example, it is a monotonically increasing transformation of the elasticity of substitution in demand ($\frac{1}{1-\alpha}$) between the two rivals' outputs in any industry. Given a firm's share λ of industry revenue, α is also a monotonically increasing transformation of the elasticity of demand $\frac{1-\alpha\lambda}{1-\alpha}$ faced by the firm. Furthermore, given λ , α is a monotonically decreasing function of the measure of market power used in the related empirical research by Nickell (1996), namely the share of profits in value added, which in this model is $(1-\alpha)/(1-\alpha\lambda)$.

The limiting case of $\alpha = 0$ defines the minimal degree of competition; in this case equations (2) ~ (4) can still be solved for revenues, prices and profits even though the utility function (1) is not defined. The opposite limiting case of $\alpha = 1$ is the case of Bertrand competition between undifferentiated products, which results in perfect competition when the two firms have the same unit cost.

A firm engages in R&D in order to decrease its relative cost. According to (5), the advantage of a cost reduction, and the disadvantage of a rival's cost reduction, depends on the degree of product market competition. Thus to examine the effects of competition on growth we need to characterize the profit function ϕ .

In the appendix we demonstrate:

Proposition 1 *For all $z > 0$: (a) The function $\phi(z, \alpha)$ is strictly decreasing in z for all $\alpha \in (0, 1)$; (b) $\phi(z, 0) = 1/2$; and (c) $\phi(z, \alpha) + \phi(1/z, \alpha) > 2\phi(1, \alpha)$ for all $\alpha \in (0, 1]$ except when $z = 1$.*

Part (a) states that a lower relative cost is always strictly advantageous to a firm, except perhaps in the extreme cases of zero or perfect competition

($\alpha = 0$ or 1).

Part (b) states that when the degree of competition falls to zero a firm's profit becomes independent of its relative cost; that is, when $\alpha = 0$ each firm faces a unit-elastic demand function, and produces an infinitesimal amount for an infinite price, yielding a revenue equal to $1/2$, at negligible cost, regardless of c_j . Because of this, the incentive to innovate vanishes when $\alpha = 0$. This is the key to our anti-Schumpeterian finding below to the effect that growth is enhanced, at least initially, by more competition.

Part (c) states that, when there is more than the minimal degree of competition, total industry profit is lower if firms are neck and neck, with identical costs, than if one firm has a relative cost advantage.

When $\alpha = 1$ we have winner-take all competition with profits determined by:

$$\phi(z, 1) = \left\{ \begin{array}{ll} 0 & \text{if } z \geq 1 \\ 1 - z & \text{otherwise} \end{array} \right\}. \quad (6)$$

Also, for all $\alpha \in (0, 1)$:

$$\phi(0, \alpha) = 1 \text{ and } \lim_{z \rightarrow \infty} \phi(z, \alpha) = 0, \quad (7)$$

$$\phi(1, \alpha) = \frac{1 - \alpha}{2 - \alpha}, \quad (8)$$

and

$$\left. \frac{\partial}{\partial z} \phi(z, \alpha) \right|_{z=1} = -\frac{\alpha}{4 - \alpha^2}. \quad (9)$$

Results (6) \sim (9) are derived in the appendix.

A firm's unit cost depends on the level of its technology. Specifically, $c_j = w\Lambda$, where w is the economy-wide wage rate, and Λ is the firm's unit labor requirement. Moreover, our normalization assumption and the linearity of utility in labor imply that $w = 1$.⁶ Thus $c_j = \Lambda$. Each time a firm's technology advances by one step, its unit labor requirement Λ falls by the

⁶The Hamiltonian of the representative household with wealth W can be expressed as:

$$H = \ln C - L + \lambda_W (rW + wL - PC),$$

where C is aggregate consumption: $\ln C \equiv \int_0^1 \ln Q_i di$, and P is its price. Our normalization implies $PC = 1$. The first-order conditions for an interior maximum with respect to C and L are: $1/C = \lambda_W P$ and $1 = w\lambda_W$. Hence $w = 1$.||

factor $\gamma > 1$. Accordingly, the relative cost of a firm that leads its rival technologically by n steps (or lags, if $n < 0$) is $z = \gamma^{-n}$.

Figure 1 shows how the firm's profit $\phi(\gamma^{-n}, \alpha)$ varies with size of its lead n and the degree of competition α .⁷ It shows that, in accordance with parts (a) and (b) of Proposition 1, profit is increasing in the firm's lead, with a rate of increase that vanishes as α approaches zero. As α increases, the relationship between lead size and profit turns into a logistic, which gets increasingly sharp. Higher α reduces the profit of a follower (a firm with $n < 0$) and of a neck-and-neck firm (with $n = 0$), but it can increase the profit of a leader (a firm with $n > 0$), especially if α and n are large.

Figure 1 here

Figure 1 reveals that the increase in a neck-and-neck firm's profit that would result from innovating and moving ahead by one step ($\phi(\gamma, \alpha) - \phi(1, \alpha)$) is strictly increasing in the degree of competition α . Thus the motive of escaping competition is potentially important for firms in the neck-and-neck state, whose pre-innovation profit is reduced by more than post-innovation profit when competition intensifies.

In contrast, Figure 1 shows that the incremental profit of a firm that already has a sizeable lead ($\phi(\gamma^{-(n+1)}, \alpha) - \phi(\gamma^{-n}, \alpha)$ where $n \gg 0$) can be inverse U-shaped in α , and that the same is true of a follower firm, whose incremental profit from catching up with the leader⁸ is $\phi(1, \alpha) - \phi(\gamma^{-n}, \alpha)$, where $n < 0$. Thus in an industry with a large technological gap we might expect an increase in competition to reduce the R&D effort of both firms when α approaches its maximal level, in accordance with the usual Schumpeterian result. For when α becomes very large neither firm in such an industry stands to make much immediate gain from innovating - - the leader

⁷Figure 1 was plotted assuming $\gamma = 1.135$. Varying γ would alter the scale of the right-hand axis, without otherwise affecting the shape of the curve.

⁸We assume that a firm that is n steps behind the leader in its industry can catch up with a single innovation, rather than having to make n innovations. Becoming a technological leader is still a step-by-step process, because it takes two innovations to go from being a laggard to being a leader. Section 6 below discusses the alternative case where the cost of catching up increases as the leader's technological lead increases. This alternative case produces results that are qualitatively similar to the case in which it takes n innovations to erase an n -step lead.

is already earning almost the maximum possible profit and the follower will still earn zero even if it catches up. However, when α is very small to begin with, incremental profits are increasing in α for all firms, and the motive to escape competition is the dominant one, since all firms earn the same profit regardless of technology level when $\alpha = 0$.

2.3 R&D and innovations

Innovative advance, and hence growth, happen at a rate determined by R&D efforts. Each industry is assumed to be duopolistic in respect of R&D as well as production.⁹ By employing $\psi(x)$ units of labor in R&D, a firm at the technological frontier (either a leader or a neck-and-neck firm) moves one step ahead with Poisson hazard rate x , and by employing $\psi(x)$ units of labor on R&D, a technological follower catches up with its rival at hazard rate $(x+h)$, where the R&D-cost function $\psi(x)$ is an increasing and convex function of R&D effort $x \geq 0$, and $h \geq 0$ is a parameter that measures the ease of imitation or R&D spillovers¹⁰. In parallel with our interpretation of α , we interpret the “ease of imitation” h as proxying the absence of institutional, legal and regulatory impediments (especially connected with patent laws and regulations) that prohibit the direct use of rivals’ technological discoveries.

We focus on the symmetric stationary equilibria in Markov strategies, in which each firm’s R&D effort depends only on its current technological state (i.e. on the technological gap in the industry to which the firm belongs and on whether the firm is a leader or a follower in that industry) and not on

⁹This duopolistic assumption is strong for two reasons at least. First, it implies that innovations are only made by firms currently in the market. Second, it excludes another interpretation of greater product market competition in terms of relaxing entry barriers in a way that leads to an increased number of firms in the industry. However to some extent the latter interpretation is captured by the comparison between the monopolistic and duopolistic industry cases carried out in Aghion et al. (1997). In particular, the analysis in that paper reveals that whenever the interest rate r is not too large, growth is greater under duopoly than under monopolistic competition. More generally, allowing for new entry would presumably reinforce the effects of product market competition as parametrized and analysed in the present paper.

¹⁰All our qualitative analytical results with respect to the effects of competition and imitation on growth would go through with minor alteration, if instead of exactly catching up with the leader in the same industry, an innovating laggard acquired a *small* lead over the current leader; in other words our results would essentially go through if we replaced the step-by-step innovations with the assumption of a sufficiently small leap-frogging.

the firm, on the industry to which the firm belongs or on the time. Such equilibria always exist in our model. Moreover they are unique when γ is close to 1. (Cf. Budd et al., 1993) We also restrict attention to the case in which the R&D-cost function is quadratic:

$$\psi(x) = \beta x^2/2, \quad \beta > 0.$$

This restriction introduces no loss of generality into our analysis of the case where γ is near 1, because the asymptotic expansions of Section 4 below do not go beyond the third order. (Cf. Budd et al., 1993.) Moreover it ensures that equilibrium is unique in the case where γ is large.¹¹

Let x_0 , x_n and \bar{x}_n denote respectively the R&D efforts of a neck-and-neck firm, a leader in an industry with gap $n \geq 1$ and a follower in such an industry, and let V_0 , V_n and \bar{V}_n denote the expected present value of their respective profits. Since the equilibrium rate of interest is the rate of time preference r , the value V_n can be derived heuristically from the Bellman equation:

$$V_n = \max_x \{(\pi_n - \beta x^2/2)dt + e^{-rdt}[xdtV_{n+1} + (\bar{x}_n + h)dtV_0 + (1 - xdt - (\bar{x}_n + h)dt)V_n]\},$$

where the R&D effort \bar{x}_n of the follower is taken as given by the leader.

In words, the value of currently being a technological leader in an industry with gap n at date t equals the discounted value at date $(t + dt)$, plus the current profit flow $\pi_n dt$, minus the current R&D cost $(\beta x^2/2)dt$, plus the discounted expected capital *gain* from making an innovation and thereby moving one further step ahead of the follower, minus the discounted expected capital *loss* from having the follower catch up.

For dt small, $e^{-rdt} \sim 1 - rdt$ and the second-order terms in (dt) can be ignored. Then the above equation can be rewritten as:

$$rV_n = \pi_n + x_n(V_{n+1} - V_n) + (\bar{x}_n + h)(V_0 - V_n) - \beta(x_n)^2/2. \quad (10)$$

¹¹There are other cases in which equilibrium is unique. For example, it is unique when r is large, h is large or β is large, even without the special choice for the R&D-cost function. (Cf. Budd et al., 1993.)

Similarly, one can derive the Bellman equations for \bar{V}_n and V_0 :

$$r\bar{V}_n = \bar{\pi}_n + x_n(\bar{V}_{n+1} - \bar{V}_n) + (\bar{x}_n + h)(V_0 - \bar{V}_n) - \beta(\bar{x}_n)^2/2. \quad (11)$$

and:

$$rV_0 = \pi_0 + x_0 \overbrace{(V_1 - V_0)}^{\text{R\&D effort of rival}} + \widehat{x_0}(\bar{V}_1 - V_0) - \beta(x_0)^2/2. \quad (12)$$

Each firm will choose its R&D effort so as to maximize the right-hand size of its Bellman equation. Thus each R&D effort is strictly proportional to the incremental value that would result from innovating:¹²

$$x_n = (V_{n+1} - V_n) / \beta, \quad (13)$$

$$\bar{x}_n = (V_0 - \bar{V}_n) / \beta, \quad (14)$$

and:¹³

$$x_0 = (V_1 - V_0) / \beta. \quad (15)$$

Equations (10) ~ (15) solve recursively for the sequence $\{x_n, \bar{x}_{n+1}, V_n, \bar{V}_{n+1}\}_{n \geq 0}$.

2.4 Steady-state industry structure

Let μ_n denote the steady-state fraction of industries with technological gap $n \geq 0$. We naturally have:

$$\sum_{n \geq 0} \mu_n = 1. \quad (16)$$

Stationarity implies that for any technological gap n (“state n ”) the flow of industries *into* state n must equal the flow *out*. Consider first state 0 (the “neck-and-neck” state). During time interval dt , in $\mu_n(\bar{x}_n + h)dt$ industries with technological gap $n \geq 1$ the follower catches up with the leader; hence the total flow of industries *into* state 0 is:

$$\sum_{n \geq 1} \mu_n(\bar{x}_n + h)dt.$$

¹²We can ignore corner solutions when deriving (13) ~ (15) because the incremental value is never negative.

¹³To derive (15), note that when choosing its R&D effort x_0 optimally, each neck-and-neck firm takes as given the R&D effort of its rival, which also equals x_0 in a symmetric Markov equilibrium.

On the other hand, in $\mu_0(2x_0)dt$ neck-and-neck industries one firm acquires a lead, hence the total flow of industries out of state 0 is $2\mu_0x_0dt$. Thus:

$$2\mu_0x_0 = \sum_{n \geq 1} \mu_n(\bar{x}_n + h). \quad (17)$$

Replicating the same reasoning for state 1 and then for states $n \geq 2$ yields:

$$\mu_1(x_1 + \bar{x}_1 + h) = 2\mu_0x_0 \quad (18)$$

and

$$\mu_n(x_n + \bar{x}_n + h) = \mu_{n-1}x_{n-1}, n \geq 2. \quad (19)$$

2.5 Steady-state growth rate

Let Y denote aggregate output, defined by: $\ln Y = \int_0^1 \ln Q_i di$. The economy's growth rate is $g = \frac{d}{dt} \ln Y$. Since each $\ln Q_i$ follows an independent and identical stochastic process, the growth rate g equals the asymptotic growth rate of each sector: $g = \lim_{\Delta t \rightarrow \infty} \frac{\Delta \ln Q_i}{\Delta t}$. An industry i is said to go through a $(p+1)$ -cycle if the technological gap n goes through the sequence $\{0, 1, \dots, p-1, p, 0\}$. The value of $\ln Q_i$ rises by $\ln \gamma^p = p \ln \gamma$ between the beginning and the end of a $(p+1)$ -cycle. Thus over any long time interval, $\Delta \ln Q_i$ can be approximated by:

$$\Delta \ln Q_i \simeq \sum_{p \geq 1} \#_p (p \ln \gamma),$$

where $\#_p$ is the number of $(p+1)$ -cycles the industry has gone through over the interval. Accordingly:

$$g = \lim_{\Delta t \rightarrow \infty} \sum_{p \geq 1} \left(\lim_{\Delta t \rightarrow \infty} \frac{\#_p}{\Delta t} \right) (p \ln \gamma),$$

where $\lim_{\Delta t \rightarrow \infty} \frac{\#_p}{\Delta t}$ is the asymptotic frequency of $(p+1)$ -cycles. This asymptotic frequency equals the steady-state flow of industries from state p to state 0, which in turn equals the fraction μ_p of industries in state p times the flow probability $(\bar{x}_p + h)$ that the follower catches up with the leader in such an industry. Hence:

$$g = \sum_{p \geq 1} \mu_p (\bar{x}_p + h) (p \ln \gamma),$$

which, using the stationarity conditions (17) \sim (19), can be rewritten as:¹⁴

$$g = (2\mu_0x_0 + \sum_{k \geq 1} \mu_k x_k) \ln \gamma. \quad (\text{G})$$

Equation (G) states that the growth rate equals the product of the frequency of “frontier innovations” (innovations by industry leaders and neck-and-neck firms, which advance the industry’s frontier technology) and the (log) size of innovations. It shows one way in which neck-and-neck rivalry promotes growth; that is, when an industry is neck and neck there are two firms trying to advance the industry’s frontier technology, whereas in any other state just one firm is trying. Thus if all the efforts x were the same, technology would advance on average twice as fast in a neck-and-neck industry as in any other. Moreover, as we shall see, the R&D effort of a neck-and-neck firm is typically greater than that of any leader.

¹⁴To see this, note first that:

$$\begin{aligned} \sum_{p \geq 1} \mu_p \cdot (\bar{x}_p + h)p &= \sum_{p \geq 1} \mu_p(\bar{x}_p + h) \\ &+ \sum_{p \geq 2} \mu_p(\bar{x}_p + h) + \sum_{p \geq 3} \mu_p(\bar{x}_p + h) + \dots \end{aligned}$$

Now, from equation (17), we know that

$$\sum_{p \geq 1} \mu_p(\bar{x}_p + h) = 2\mu_0x_0.$$

Using (17) \sim (19), one can also straightforwardly show that:

$$\sum_{p \geq k} \mu_p(\bar{x}_p + h) = \mu_{k-1}x_{k-1}$$

for all $k \geq 2$. This establishes (G).||

3 Very large innovations¹⁵

In this section we discuss the special case in which the maximum permissible lead is one step. That is, we assume that a firm one step ahead of its rival cannot perform R&D. This special case approximates what happens when the size of innovations γ is very large. This is because in the limit, as $\gamma \rightarrow \infty$, result (7) above implies that even without the special restriction of this section the equilibrium R&D effort of the leading firm would approach zero. That is, when γ is very large, even a one-step lead would raise the leader's profit almost to the maximal level ($\phi(\gamma^{-1}, \alpha) \simeq 1$ for $\alpha > 0$), where there is no further incentive to innovate. This case allows maximum simplicity and allows our results to be derived analytically.

Let $\Gamma_0 \equiv \pi_1 - \pi_0$ and $\Gamma_{-1} \equiv \pi_0 - \bar{\pi}_1$ denote respectively the incremental profit of a neck-and-neck firm and a follower. Equations (10) \sim (12), (14) and (15), together with the restriction that the leader's R&D effort x_1 be zero, imply that \bar{x}_1 and x_0 are determined by:

$$x_0^2/2 + (r + h)x_0 = \Gamma_0/\beta \quad (20)$$

$$\bar{x}_1^2/2 + (r + h + x_0)\bar{x}_1 = \Gamma_{-1}/\beta + x_0^2/2 \quad (21)$$

It follows directly from (20) that the R&D effort of a neck-and-neck firm is always increased by an increase in competition, which we have seen always increases the incremental profit Γ_0 , and is always reduced by an increase in the ease of imitation, which raises the effective discount rate $r + h$.

By Proposition 1(c), $\Gamma_0 > \Gamma_{-1}$. It follows from this, using (20) and (21), that a firm's greatest R&D effort occurs when it is in a neck-and-neck industry:

$$x_0 > \bar{x}_1. \quad (22)$$

¹⁵For an analysis of this example which first takes the profit flows π_n and $\bar{\pi}_n$ as primary parameters, but then compares between Cournot and Bertrand competition and between step-by-step and leap-frogging technological progress, we again refer the reader to Aghion et al. (1997). Mukoyama (1999) has independently extended this analysis to look at the effects of competition with a fixed labor supply, in the special case where $\alpha = 1$. In his analysis, the two-state model can be exactly correct even without very large innovations because a constant-returns R&D technology implies, for some parameter values, that the Arrow-effect dissuades technology leaders from performing R&D.

The steady-state equation (17) implies that:

$$2\mu_0x_0 = \mu_1(\bar{x}_1 + h) = (1 - \mu_0)(\bar{x}_1 + h)$$

Substituting this into the growth rate equation (G) yields:

$$g = \mu_0 2x_0 \ln \gamma = \frac{2x_0(\bar{x}_1 + h)}{2x_0 + \bar{x}_1 + h} \ln \gamma, \quad (23)$$

which, together with (20) and (21), determines the steady-state growth rate g as a function of r, h, β, Γ_0 and Γ_{-1} .

According to (23), the growth rate is proportional to the probability (μ_0), and to the total R&D effort ($2x_0$), of a neck-and-neck industry. The effects of competition (α) and imitation (h) on growth can be understood in terms of their effects on these two characteristics of a neck-and-neck industry.

An increase in product market competition always has the initial effect of raising growth; that is, holding constant the ease of imitation h , the growth rate increases as the degree of competition α is raised above zero. This is because when $\alpha = 0$ each firm earns the same profit regardless of its technological lead or lag (recall Proposition 1(b)). Thus no firm has any incentive to innovate, and the R&D effort of a neck-and-neck industry is zero.¹⁶ By raising the degree of competition above zero we make the incremental profit Γ_0 positive for neck-and-neck firms; this gives them a reason to innovate, namely to escape competition, with the result that growth rises above zero.¹⁷

Whether the effect of competition on growth is always positive cannot be determined without making more assumptions. This is because, as we pointed out in our discussion of Figure 1 above, an increase in the intensity of competition can eventually *reduce* the incremental profit Γ_{-1} of follower firms. When this happens, then according to (21) the follower's R&D effort \bar{x}_1 can fall. This can reduce the economy's growth rate, as in other Schumpeterian models. Specifically, it can reduce g by reducing the probability of a neck-and-neck industry ($\mu_0 = (\bar{x}_1 + h)/(2x_0 + \bar{x}_1 + h)$).

An increase in imitation eventually has the usual Schumpeterian appropriability effect of reducing the growth rate. It does this by reducing the

¹⁶Formally, $\Gamma_0 = 0$ and hence by (20), $x_0 = 0$.

¹⁷When $\alpha > 0$, then, by (9) above, $\Gamma_0 > 0$ and $\Gamma_{-1} > 0$, so that, by (20) and (21), $x_0 > 0$ and $\bar{x}_1 > 0$; from this and (23) it follows that $g > 0$.

total R&D effort of a neck-and-neck industry ($2x_0$). That is, according to (20), as $h \rightarrow \infty$, x_0 falls to zero. Since, by (G), $0 < g < 2x_0 \ln \gamma$, the growth rate also falls to zero.

Although imitation reduces x_0 , it also increases the probability μ_0 of a neck-and-neck industry, by inducing more frequent catch-up. This composition effect works in opposition to the usual Schumpeterian effect, and tends to raise the growth rate. Because of it, a little imitation is always good for growth. That is, when $h = 0$, $\partial g / \partial h > 0$.¹⁸

Thus we see that when the size of innovations γ is large enough to make this two-state example applicable, a little competition and a little imitation are always good for growth, contrary to the usual Schumpeterian appropriability effects. Yet, in the case of imitation at least, the Schumpeterian effect is eventually valid, so that growth depends on the ease of imitation according to an inverse-U shaped function.

4 Very small innovations

In the previous section we analysed the case where innovations were very large, in the sense that γ was close to its upper bound of $+\infty$. In the present section we go to the opposite extreme: we analyze the case where innovations are very small, in the sense that γ is close to its lower bound of 1. As in Budd et al. (1993), we use the method of asymptotic expansions. In order

¹⁸To see this, note that, from (23):

$$\partial g / \partial h|_{h=0} = \left[\frac{2x_0}{\bar{x}_1} \left(1 + \frac{\partial \bar{x}_1}{\partial h} \Big|_{h=0} \right) + \frac{\bar{x}_1}{x_0} \frac{\partial x_0}{\partial h} \Big|_{h=0} \right] \left[\frac{2x_0 \bar{x}_1 \ln \gamma}{(2x_0 + \bar{x}_1)^2} \right], \quad (24)$$

and from (20):

$$\frac{\partial x_0}{\partial h} \Big|_{h=0} = -\frac{x_0}{x_0 + r}. \quad (25)$$

From (21) and (25):

$$\frac{\partial \bar{x}_1}{\partial h} \Big|_{h=0} = -\frac{\bar{x}_1 + (x_0 - \bar{x}_1) \frac{x_0}{x_0 + r}}{x_0 + \bar{x}_1 + r}. \quad (26)$$

From (24) \sim (26):

$$\partial g / \partial h|_{h=0} \sim \frac{2x_0}{\bar{x}_1} \frac{(x_0 + r)^2 - (x_0 - \bar{x}_1)x_0}{x_0 + \bar{x}_1 + r} - \bar{x}_1. \quad (27)$$

It can be shown, using (22), that the right-hand side of (27) is positive.||

to cover the whole range of values of α , we need to derive two different sets of expansions: one that is valid for α in any compact subinterval S of $[0, 1)$; and one that is valid for $\alpha = 1$. This is because, as indicated by results (6) and (9) above, the profit function $\phi(\cdot, \alpha)$ is smooth when $\alpha < 1$, but has a kink at 1 when $\alpha = 1$. By combining these expansions, we obtain a complete picture of the way growth varies with h and α .

4.1 The case $\alpha < 1$

Suppose that $\alpha < 1$. Put $\varepsilon = \gamma - 1$. Then, as we show in the Appendix, the value functions can be approximated by the expansions

$$V_n = \frac{\phi(1, \alpha)}{r} + n\beta\eta\varepsilon + O(\varepsilon^2), \quad (28)$$

$$V_0 = \frac{\phi(1, \alpha)}{r} + O(\varepsilon^2) \quad (29)$$

and

$$\bar{V}_n = \frac{\phi(1, \alpha)}{r} - n\beta\eta\varepsilon + O(\varepsilon^2), \quad (30)$$

where

$$\eta = \frac{1}{\beta(r+h)} \left(-\frac{\partial\phi(1, \alpha)}{\partial z} \right) > 0. \quad (31)$$

Moreover the probability μ_0 of the neck-and-neck state can be approximated by the expansion

$$\mu_0 = \hat{\mu}_0 + O(\varepsilon), \quad (32)$$

where

$$\hat{\mu}_0 = \frac{1}{1 + 2f\left(\frac{h}{\eta\varepsilon}\right)} \quad (33)$$

and

$$f(\zeta) \equiv \sum_{k=2}^{\infty} \left(\frac{1}{2+\zeta} \cdots \frac{1}{k+\zeta} \right).^{19}$$

A useful property of this function $f(\zeta)$, which we establish in the appendix, is that:

$$-1 < \frac{\zeta f'(\zeta)}{f(\zeta)} < 0. \quad (34)$$

¹⁹One can actually reexpress this function as: $f(\zeta) \equiv \int_0^1 e^{-y} y^{1+\zeta} dy$.

For our purposes, the most important aspect of the expansions for the values is that they are linear in the lead-size n . Since the incentive for a leader or a neck-and-neck firm to innovate depends on the incremental value from going ahead one step, this linearity means that when γ is small each of these firms will spend approximately the same on R&D. Since the incentive for a follower to innovate depends on the difference between the value of being even and the value of being behind n steps, the same linearity means that when γ is small the follower's R&D effort will be approximately proportional to n . In other words:

$$x_n = (V_{n+1} - V_n) / \beta = \eta\varepsilon + O(\varepsilon^2), \quad (35)$$

$$x_0 = (V_1 - V_0) / \beta = \eta\varepsilon + O(\varepsilon^2) \quad (36)$$

and

$$\bar{x}_n = (V_0 - \bar{V}_n) / \beta = n\eta\varepsilon + O(\varepsilon^2). \quad (37)$$

Now, we have

$$g = \left(2\mu_0 x_0 + \sum_{n=1}^{\infty} \mu_n x_n \right) \ln \gamma$$

(by equation (G))

$$= \left(\mu_0 x_0 + \sum_{n=0}^{\infty} \mu_n x_n \right) \ln \gamma$$

(rearranging)

$$= \left((\hat{\mu}_0 + O(\varepsilon)) (\eta\varepsilon + O(\varepsilon^2)) + \sum_{n=0}^{\infty} \mu_n (\eta\varepsilon + O(\varepsilon^2)) \right) (\varepsilon + O(\varepsilon^2))$$

(using the expansion (32) for μ_0 , the expansions (35-36) for the x_n and the fact that $\ln \gamma = \varepsilon + O(\varepsilon^2)$)

$$= ((\hat{\mu}_0 + O(\varepsilon)) (\eta\varepsilon + O(\varepsilon^2)) + (\eta\varepsilon + O(\varepsilon^2))) (\varepsilon + O(\varepsilon^2))$$

(because $\sum_{n=0}^{\infty} \mu_n = 1$)

$$= (1 + \hat{\mu}_0) \eta\varepsilon^2 + O(\varepsilon^3).$$

According to this equation, the growth rate in the neighborhood of $\gamma = 1$ is proportional to the product of: (i) one plus the probability of a neck-and-neck industry $1 + \hat{\mu}_0$; and (ii) the R&D effort $\eta\varepsilon$ of a neck-and-neck

firm. Thus, once again, growth is increased by any parameter change that increases either of these characteristics of a neck-and-neck industry. The neck-and-neck state is critical in this case because although each leader's R&D effort is approximately the same as a neck-and-neck firm's, there are two frontier innovators in the neck-and-neck state. Therefore the frontier technology advances twice as fast in the neck-and-neck industry as in any other industry.

Consider an increase in the degree of competition α . Equations (9) and (31) together imply that $\frac{\partial \eta}{\partial \alpha} > 0$. It follows that the approximate R&D effort $\eta\varepsilon$ of each neck-and-neck firm is increasing in α . This is consistent with what we conjectured when discussing Figure 1, namely that the incentive to innovate (incremental value) of a neck-and-neck firm is increasing in the degree of product-market competition. On the other hand, equation (33) and the fact that $f' < 0$ together imply that $\frac{\partial \hat{\mu}_0}{\partial \eta} < 0$. It follows that the approximate probability $\hat{\mu}_0$ of the neck-and-neck state is decreasing in α . The increase in neck-and-neck R&D effort is therefore counteracted by a negative composition effect. Finally, substituting for $\hat{\mu}_0$ from (33), we have

$$(1 + \hat{\mu}_0) \eta\varepsilon = \frac{2 \left(1 + f \left(\frac{h}{\eta\varepsilon} \right) \right)}{\frac{h}{\eta\varepsilon} \left(1 + 2f \left(\frac{h}{\eta\varepsilon} \right) \right)} h. \quad (38)$$

Moreover, using the fact that $\frac{\zeta f'(\zeta)}{f(\zeta)} > -1$, it can be shown that $\frac{2(1+f(\zeta))}{\zeta(1+2f(\zeta))}$ is decreasing in ζ . The overall effect of an increase in α is therefore an increase in growth. In particular, there is no evidence of a Schumpeterian appropriability effect of competition on growth.

Consider now the effect of an increase in the intensity of imitation h . Equation (31) implies that $\frac{\partial \eta}{\partial h} < 0$. It follows that the approximate R&D effort $\eta\varepsilon$ of each neck-and-neck firm is decreasing in h . This is the usual Schumpeterian effect of increasing the intensity of imitation. On the other hand, equation (31) implies that $\frac{h}{\eta\varepsilon}$ is increasing in h . Equation (33) and the fact that $f' < 0$ then implies that $\frac{\partial \hat{\mu}_0}{\partial h} > 0$. The decrease in neck-and-neck R&D effort is therefore counteracted by a positive composition effect. Finally, it is easy to verify that the right-hand side of equation (38): (i) converges to a strictly positive limit as $h \rightarrow 0+$; (ii) has a strictly positive

derivative with respect to h at $h = 0$; and (iii) converges to 0 as $h \rightarrow +\infty$. These simple observations suggest that, as in the case of large innovations, the approximate growth rate is inverse-U shaped with respect to h : the composition effect of forcing firms more frequently into the R&D-intensive neck-and-neck state will cause g to increase when h first rises above zero, but the usual Schumpeterian appropriability effect will eventually cause g to decrease when h continues to increase.

4.2 The case $\alpha = 1$

Suppose now that $\alpha = 1$. Put $\varepsilon = \gamma - 1$ as before, and put

$$\psi = \frac{1}{\beta(r+h)}.$$

Then, as we show in the Appendix: the approximate linearity in n of the profit function for a leader implies that

$$V_n = n\beta\psi\varepsilon + O(\varepsilon^2); \quad (39)$$

and the fact that only a leader earns a positive profit implies that

$$V_0 = O(\varepsilon^2) \quad (40)$$

and

$$\bar{V}_n = O(\varepsilon^2). \quad (41)$$

Moreover the probability μ_0 of the neck-and-neck state can be approximated by the expansion

$$\mu_0 = \tilde{\mu}_0 + O(\varepsilon),$$

where

$$\tilde{\mu}_0 = \frac{1}{1 + 2\frac{\psi\varepsilon}{h}}. \quad (42)$$

Hence, to the first order, only leaders and neck-and-neck firms perform R&D, and all at the same rate:

$$x_n = \psi\varepsilon + O(\varepsilon^2),$$

$$x_0 = \psi\varepsilon + O(\varepsilon^2)$$

and

$$\bar{x}_n = O(\varepsilon^2).$$

Moreover the approximate growth rate can be expressed in terms of the neck-and-neck effort x_0 and frequency $\tilde{\mu}_0$:

$$g = (1 + \tilde{\mu}_0) \psi \varepsilon^2 + O(\varepsilon^3).$$

Now: $\psi \varepsilon$ is decreasing in h ; $\tilde{\mu}_0$ is increasing in h ; and we have

$$(1 + \tilde{\mu}_0) \psi \varepsilon = \frac{2 \left(1 + \frac{\psi \varepsilon}{h}\right)}{\frac{h}{\psi \varepsilon} \left(1 + 2 \frac{\psi \varepsilon}{h}\right)} h. \quad (43)$$

Finally, it is easy to verify that the right-hand side of equation (43): (i) converges to a strictly positive limit as $h \rightarrow 0+$; (ii) has a strictly positive derivative with respect to h at $h = 0$ (because the partial derivative with respect to h generates the dominant term); and (iii) converges to 0 as $h \rightarrow +\infty$.

4.3 Comparing the two approximations

In order to determine how g varies globally with α , we can compare the two quantities

$$g_0(h, \alpha) = \frac{2 \left(1 + f\left(\frac{h}{\eta \varepsilon}\right)\right)}{\frac{h}{\eta \varepsilon} \left(1 + 2f\left(\frac{h}{\eta \varepsilon}\right)\right)} h$$

and

$$g_1(h) = \frac{2 \left(1 + \frac{\psi \varepsilon}{h}\right)}{\frac{h}{\psi \varepsilon} \left(1 + 2 \frac{\psi \varepsilon}{h}\right)} h.$$

We have

$$\frac{2 \left(1 + f\left(\frac{h}{\eta \varepsilon}\right)\right)}{1 + 2f\left(\frac{h}{\eta \varepsilon}\right)} < \frac{2 \left(1 + 2f\left(\frac{h}{\eta \varepsilon}\right)\right)}{1 + 2f\left(\frac{h}{\eta \varepsilon}\right)} = 2$$

and

$$\frac{2 \left(1 + \frac{\psi \varepsilon}{h}\right)}{1 + 2 \frac{\psi \varepsilon}{h}} > \frac{2 \left(1 + \frac{\psi \varepsilon}{h}\right)}{2 + 2 \frac{\psi \varepsilon}{h}} = 1.$$

Hence

$$\frac{g_0(h, \alpha)}{g_1(h)} < \frac{2\eta}{\psi} = -2 \frac{\partial \phi(1, \alpha)}{\partial z}.$$

Moreover (9) tells us that $\lim_{\alpha \rightarrow 1-} \frac{\partial \phi(1, \alpha)}{\partial z} = -\frac{1}{3}$. Hence $\lim_{\alpha \rightarrow 1-} \frac{g_0(h, \alpha)}{g_1(h)} \leq \frac{2}{3}$.

In other words, when γ is small enough, growth is monotonically increasing in α on the entire interval $[0, 1]$.

4.4 The global picture

At this point we have found an approximation for the growth rate for all $h \in (0, +\infty)$ and all $\alpha \in [0, 1]$. Moreover: we have shown that, for all $h \in (0, +\infty)$, the approximate growth rate is increasing in $\alpha \in [0, 1]$ with an upward jump at $\alpha = 1$; and we have argued that, for all $\alpha \in [0, 1]$, the approximate growth rate is inverse-U shaped with respect to $h \in (0, +\infty)$.

Figure 2 depicts the approximate growth rate, as a function of α and h , for the case where $\varepsilon = 0.0001$ and where all other parameters are taken from the baseline case to be described in the following section. The monotonicity with respect to α , the inverse-U shape with respect to h , and the upward jump at $\alpha = 1$ are all apparent from this figure. The actual growth rate, as computed from the general model according to the procedures described in the following section, is also shown in Figure 2. This indicates that the combined expansions provide a very close approximation to the actual growth rate, and confirms the above effects of competition and imitation.

Figure 2 here

To summarize, in the case of very small innovations, the usual Schumpeterian appropriability effect of competition on growth vanishes entirely: growth is always enhanced by more competition, because more competition raises the incentive for a firm to escape competition by innovating. Also, as in the case of large innovations, the growth rate depends on the ease of imitation according to an inverse-U shaped relationship: more imitation eventually has the Schumpeterian effect of reducing growth, but it always has the initial effect of raising growth by promoting neck-and-neck rivalry.

5 The general case

In this section we analyse the general case in which there is no restriction on the size of innovations. We begin by noting that two of the results demonstrated in the previous sections extend easily to the general case. First, a little competition is always good for growth. This is because when the degree of competition is minimal ($\alpha = 0$), a firm's value is independent of its

technological lead; as we have seen, it always earns a profit equal to $1/2$. Thus no firm has an incentive to perform R&D, equations (10) ~ (15) yield $x_n = \bar{x}_n = 0$ for all n , and the steady-state growth rate is zero. When the degree of competition rises a little above zero however, a firm's profit depends positively on the size of its technological lead, so that leaders and neck-and-neck firms have an incentive to perform at least some R&D, given that the marginal cost of R&D is zero when R&D effort is zero. Thus according to the growth equation (G) the growth rate will be positive when the degree of competition rises above zero.²⁰

The other aspect of our main result that generalizes easily is that a lot of imitation is bad for growth. If the ease of imitation h approaches infinity, any lead that a firm might establish vanishes almost instantaneously, reducing the erstwhile leader's profit back to π_0 . This eliminates any incentive for leaders and neck-and-neck firms to perform R&D. Likewise it eliminates any incentive for followers to perform R&D, since they would soon catch up even without any such effort. Formally, as h approaches infinity, the values V_0 , V_n and \bar{V}_n determined by (10) ~ (15) all approach the same limit π_0/r , and the equilibrium R&D efforts x_0 , x_n and \bar{x}_n all approach zero. Hence the growth rate determined by (G) approaches zero.

This leaves unanswered the questions of whether a little imitation might raise growth, and whether a lot of competition might reduce growth. To address these questions in the general case we solve the model numerically. To deal with the infinite number of states n we first suppose provisionally that once a firm's lead reaches a finite upper limit N it can no longer perform R&D. This limits to N the number of states with positive probability in the steady-state distribution and reduces (10) ~ (15) to a finite system²¹ that can be solved numerically. We then increase N until the steady-state probability of a lead size within 10 percent of N has fallen below 10^{-3} .

In the numerical analysis we fix the rate of interest at²² $r = .03$, and

²⁰The appendix shows formally that if $\alpha > 0$ and $h > 0$ then $g > 0$.

²¹When $N = 1$ the system is exactly that of Section 3.

²²Since the numeraire is consumer expenditures and the wage rate equals unity, (footnote 6 above) therefore r is a labor rate of interest. The more conventional real rate of interest is $r + g$, which in the benchmark case equals .05.

consider a range of values for the size of innovations γ . The only other parameter of the model other than α and h is the slope β of the marginal R&D-cost function. We first consider a benchmark case in which γ and β are chosen to make the average growth rate over all values of α equal to 0.02 and the average fraction of GDP spent on R&D over all values of α equal to 0.025, when $h = 0$. Thus the benchmark case is calibrated roughly to the US post-war economy with the time unit interpreted as one year. It has $\gamma = 1.135$ and $\beta = 0.8$. We hold β fixed at this level when we vary γ above and below its benchmark value.

Figure 3 depicts a firm's value at various leads, normalized so that its neck-and-neck value is zero ($V_n - V_0$ when $n \geq 0$, and $\bar{V}_{-n} - V_0$ when $n < 0$). It is plotted against the degree of competition α in panel (a) and against the ease of imitation h in panel (b). Evidently the value function inherits much of its shape from the profit function. Specifically, its slope with respect to n is positive but vanishes as α falls to zero. The slope also falls uniformly as the ease of imitation h increases. The curvature of the logistic with respect to n increases with α , and the value of catching up ($V_0 - \bar{V}_{-n}$ for $n < 0$) is small for extreme values of α .

Figure 3 here

Since the slope of the value function measures a leader's incentive to innovate, the fact that it is maximal around the neck-and-neck point makes the neck-and-neck state especially important quantitatively; neck-and-neck firms perform R&D at a higher intensity than industry leaders. Thus a greater degree of competition will tend to raise growth by sharpening the logistic shape of the value function and thereby raising the incentive for firms in the critical neck-and-neck state to perform R&D.

Figure 4 depicts a firm's R&D effort at various leads. It shows that, in accordance with our discussion in the previous paragraph, a neck-and-neck firm (with $n = 0$) does more R&D than a leader firm (with $n > 0$). As the degree of competition rises the R&D effort of neck-and-neck firms increases. The effect of increasing α on R&D by followers (firms with $n < 0$) is first positive but then negative, because the value of catching up is small

for extreme values of α . However, a follower's R&D effort does not vanish when $\alpha = 1$ because even though the follower's immediate profit cannot be increased by catching up, the prospect of taking the lead is enhanced by catching up. The effect of increasing the ease of imitation h is to dampen all R&D efforts, because it reduces the slope of the value function.

Figure 4 here

Figure 5 depicts the steady-state distribution of technological leads. As α increases, the probability of neck-and-neck rivalry ($n = 0$) diminishes steadily. One reason for this is that, as we have seen, the incentive of neck-and-neck firms to perform R&D increases, and hence the rate at which industries exit the neck-and-neck state increases. Another reason that applies for large values of α is that, as we have also seen, the incentive for a follower to catch up diminishes as the degree of competition gets very large, because of the usual Schumpeterian effect of a reduced prospect of immediate neck-and-neck profit in the event that the R&D results in an innovation. For both of these reasons, an increase in α reduces the probability of the critical neck-and-neck state in which so much R&D takes place, and hence it can possibly reduce growth.

Figure 5 here

Increases in h shift the distribution so that it becomes increasingly concentrated on the neck-and-neck state. By putting firms more often into the state with the highest frequency of frontier innovation this increase in imitation can possibly increase the growth rate. Note that the rate at which an increase in h increases the probability of $n = 0$ is greatest when $h = 0$. This makes it more likely that the growth-enhancing industry-composition effect of increased imitation dominates when h is small than when the probability is already near unity.

Figure 6 depicts the steady-state growth rate g for four different values of γ ranging from 1.03 to 4. We have examined a large number of other cases (including cases with other values of r and β) without finding any exceptions to the inferences reported below. Figure 6 verifies our proposition that g

is always increasing initially with respect to the degree of competition α . It also shows however that when innovations are very large and the ease of imitation is not too large, the industry-composition effect of an increase in the degree of competition can eventually reduce the growth rate if h is held constant.

Figure 6 here

These numerical results argue strongly against the Schumpeterian proposition that competition reduces growth. For the only cases in which we have observed such an overall effect occur when γ is far too large to fit the facts concerning growth and R&D expenditures. Moreover, as Figure 6 indicates, if we allow h and α to be chosen together then the growth-maximizing value of α is always unity. That is, the degree of competition must be maximal in order to achieve the highest possible growth rate.

Figure 6 also corroborates our argument that g is eventually reduced by raising the ease of imitation. Also, in most cases g is initially increasing in h . Thus once again the industry-composition effect of putting firms more often into the R&D-intensive state of neck-and-neck rivalry appears to be the dominant one when the ease of imitation is not already too large. This does not hold true however, in cases where the degree of competition α is very large and γ is not too large. In these cases an increase in the ease of imitation always has the Schumpeterian effect, even initially, of reducing growth in the limiting case of perfect competition ($\alpha = 1$).²³ Thus the contradiction of Schumpeter that we found analytically in the first two sections when characterizing the initial effect of h is tempered by the numerical analysis.

6 Concluding remarks

We have already summarized our results in the introduction to the paper. Here we comment on some among the many possible extensions to the paper's analysis.²⁴ The first relaxes our assumption to the effect that a follower's ease

²³We have verified numerically that these initial negative effects of h are not always artifacts of the discrete grid for h used in the calculations underlying Figure 6.

²⁴The first two extensions have been suggested by a referee, to whom we are very grateful.

of imitation and R&D-cost function are independent of the technological gap n to be made up. It might be more realistic to assume that the further behind the follower becomes, the lower the ease of imitation and the higher the R&D-cost schedule.

We have investigated this possibility by assuming that the catch-up hazard rate of a firm that is n steps behind the industry leader is $(\bar{x}_n + h) e^{-\xi n}$, $\xi > 0$. Numerical analysis of this alternative model shows that, compared to the base model of the present paper, leaders and neck-and-neck firms do more R&D because of the extra marginal benefit that comes from making it more difficult for the follower to catch up, while followers do less R&D because of the extra cost. The main effect on industry composition is to reduce the relative probability of the critical neck-and-neck state, as one would expect from the changed R&D efforts.

This modification expands the region of parameter space over which the effect of competition on growth is negative, because now as α increases, holding h constant, the encouraging effect on neck-and-neck R&D is even stronger than before, which means that one reaches the point sooner than before where the steady-state probability μ_0 of neck-and-neck rivalry is so low that the growth-reducing decrease in μ_0 is the dominant effect. The reduction of μ_0 also makes it more likely that an increase in the ease of imitation will have a positive overall effect on growth because it offsets the fall in μ_0 . Otherwise the qualitative results of the numerical analysis are the same as reported above.

The second possible extension relaxes the assumption implicit in the above analysis to the effect that a successful innovator automatically implements the innovation. This assumption precludes the leader from following a strategy of shelving a successful innovation in order to keep the follower from learning the technological details by examining the product. If a follower's ability to catch up were not dependent on seeing the product, say because industrial secrecy laws were lax, then this strategy would not be used anyway, and our implicit assumption would be innocuous. But in general it might make more sense for us to allow firms the shelving option, and to suppose that when a follower catches up, it catches up not to the leader's

latest innovation but to the most advanced technology that the leader has implemented.

It can be shown that under this alternative assumption the shelving option would not be exercised in equilibrium in the two-state example of section 3 above. But in the general case, numerical analysis shows that it can indeed be an equilibrium strategy, although never for a firm whose latest innovation is only one step ahead of the follower. Our investigations of this extension have not so far changed any of the conclusions reported above.

A third extension is to consider the case of *non-unit elastic* industry demand functions. The conclusion that an increase in α is almost always growth-enhancing, which came out of both our asymptotic expansions and our simulations, should, by continuity, carry over to the case where demand functions are almost unit-elastic. Furthermore, preliminary investigation of the case where industry demand functions are more than unit elastic²⁵, confirms the inverted U-shaped effect of α on g which we had already found in the basic unit-elastic case analyzed above. Indeed, the greater the elasticity of industry demand, the greater the incentive response of a neck-and-neck firm to an increase in α : innovating will allow a neck-and-neck firm not only to move ahead of its competitor in the same industry, but also to steal more business from other sectors in the economy. This extra incentive to innovate, in turn, implies that as α increases one should get sooner to the point where the composition effect of further increasing α , dominates the direct incentive effect, at which point the correlation between α and g becomes negative.²⁶

²⁵More specifically, we have investigated the case where the intertemporal utility function of the representative consumer, is given by:

$$U = \int_0^{\infty} e^{-rt} \{\ln C_t - L(t)\} dt,$$

where, for all t :

$$C_t = \left(\int_0^1 Q_i^\beta \right)^{\frac{1}{\beta}}; \beta \in (0, 1),$$

which in turn corresponds to an elasticity of industry demand equal to: $\frac{1}{1-\beta} > 1$. (Our analysis so far has concentrated on the unit-elastic case where $\beta = 0$). In this extension of our model, within- (resp. across-) industry product market competition is measured by α (resp. β).

²⁶On the other hand, an increase in β would appear to increase the R&D incentives of technological leaders in all industries but to a larger extent in neck and neck sectors, with

Another direction in which the work in this paper could be taken, is to analyze the interplay between competition (anti-trust) policy and patent policy. Whilst earlier Schumpeterian models of endogenous growth and also much of the existing IO literature on competition and innovation, share the implication that anti-trust policy would essentially *offset* the innovation-enhancing effects of patent policy by reducing the rents accruing to successful innovators, our model in this paper suggests that the two kinds of policy may actually end up being often *complementary* in fostering R&D and growth. Indeed, we found both, that when we allow for both PMC and imitation the maximal growth rate is achieved by allowing the maximal degree of product market competition, and at the same time that too much imitation is always bad for growth. Exploring this complementarity and its implications for the design and conduct of anti-trust policy in high-tech industries, appears to be an important topic for future research.

Finally, we note that the model can serve as a basis for further empirical work on the relationship(s) between product market competition, imitation and productivity growth. For example, we have seen that PMC is most likely to reduce growth when it is already very intense initially. This prediction seems to be confirmed by recent empirical work by Blundell et al. (1995), which finds that the correlation between PMC and growth is more positive in more concentrated industries. More generally, whether the positive correlation between PMC and growth can be explained more convincingly by the “escape competition” effect analyzed in this paper than by agency considerations²⁷ or mobility effects²⁸ remains the subject of further empirical research.

a corresponding effect on aggregate growth which again should be positive or inverted U-shaped.

²⁷See Nickell et al. (1997), and Aghion et al. (1999).

²⁸See Aghion and Howitt (1996).

References

- Aghion, Philippe, Mathias Dewatripont, and Patrick Rey (1999): “Competition, Financial Discipline and Growth”, *Review of Economic Studies*, October Issue.
- Aghion, Philippe, Christopher Harris, and John Vickers (1997): “Competition and Growth with Step-by-Step Innovation: An Example.” *European Economic Review, Papers and Proceedings*, pp. 771-782.
- Aghion, Philippe, and Peter Howitt (1992): “A Model of Growth through Creative Destruction”, *Econometrica*, 60, pp. 323-351.
- Aghion, Philippe, and Peter Howitt (1996): “Research and Development in the Growth Process.” *Journal of Economic Growth*, 1, pp. 49-73.
- Aghion, Philippe, and Peter Howitt (1998): *Endogenous Growth Theory*. Cambridge, MA: MIT Press.
- Aghion, Philippe, and Mark Schankerman (1999): “Competition, Entry and the Social Returns to Infrastructure in Transition Economies.” *Economics of Transition*, 7, pp. 79-101.
- Barro, Robert J., and Xavier Sala-i-Martin (1995): *Economic Growth*. New York: McGraw-Hill.
- Blundell, R., R. Griffith, and J. Van Reenen (1995): “Dynamic Count Data Models of Technological Innovation.” *Economic Journal*, 105, pp. 333–344.
- Boone, Jan (1999): “Measuring Product Market Competition.” Unpublished, Tilburg University, October 8.
- Budd, C., C. Harris and J. Vickers (1993): “A Model of the Evolution of Duopoly: Does the Asymmetry between Firms Tend to Increase or Decrease?” *Review of Economic Studies*, 60, pp. 543-573.
- Caballero, R. J., and A. B. Jaffe (1993): “How High are the Giants’ Shoulders? An Empirical Assessment of Knowledge Spillovers and Creative Destruction in a Model of Economic Growth”, *NBER Macroeconomic Annual*, pp. 15-74.
- Davidson, Carl, and Paul Segerstrom (1998): “R&D Subsidies and Economic Growth.” *RAND Journal of Economics*, 29, pp. 548-77.

- Glass, Amy Jocelyn (1999): “Costly R&D and Intellectual Property Rights Protection.” *International Journal of Technology Management*, forthcoming.
- Glass, Amy Jocelyn, and Kamal Saggi (1999): “Intellectual Property Rights and Foreign Direct Investment.” Unpublished, Ohio State University, June.
- Grossman, G., and E. Helpman (1991): “Quality Ladders and Product Cycles”, *Quarterly Journal of Economics*, 106, pp. 557-586.
- Harris, C., and J. Vickers (1987): “Racing with Uncertainty”, *Review of Economic Studies*, 54, pp. 1-21.
- Helpman, E. (1993): “Innovation, Imitation, and Intellectual Property Rights”, *Econometrica*, 61, pp. 1246-1280.
- Mookherjee, Dilip and Debraj Ray (1991): “On the Competitive Pressure Created by the Diffusion of Innovations”, *Journal of Economic Theory*, 54, pp. 124-147.
- Mukoyama, Toshihiko (1999): “Imitation and Growth with Cumulative Technology.” Unpublished, University of Rochester, September 22.
- Nickell, Stephen (1996): “Competition and Corporate Performance.” *Journal of Political Economy* 104, pp. 724–46.
- Nickell, Stephen, Daphne Nicolitsas, and Neil Dryden (1997): “What Makes Firms Perform Well?” *European Economic Review* 41: pp. 783-96.
- Peretto, Pietro F. (1999): “Cost Reduction, Entry, and the Interdependence of Market Structure and Economic Growth.” *Journal of Monetary Economics*, 43, pp. 173-95.
- Segerstrom, Paul S. (1991): “Innovation, Imitation, and Economic Growth.” *Journal of Political Economy*, 99, pp. 807-27.
- Segerstrom, Paul S., and James M. Zolnierrek (1999): “The R&D Incentives of Industry Leaders.” *International Economic Review*, 40, pp. 745-66.
- Thompson, Peter, and Douglas Waldo (1994): “Growth and Trustified Capitalism.” *Journal of Monetary Economics*, 34, pp. 445-62.
- Vickers, John (1995) “Entry and Competitive Selection.” Unpublished.
- Zeng, Jinli (1993): “Innovative Vs. Imitative R&D and Economic Growth.” Unpublished, University of Western Ontario.

Appendix

First we prove Proposition 1. Define $z \equiv c_A/c_B$ and $\lambda \equiv \lambda_A$. Take any $\alpha \in (0, 1)$. From (2):

$$\lambda = \frac{1}{1 + \left(\frac{p_A}{p_B}\right)^{\frac{\alpha}{1-\alpha}}}. \quad (\text{A1})$$

From (3) and the fact that $\lambda_A + \lambda_B = 1$:

$$\frac{p_A}{p_B} = \frac{(1 - \alpha\lambda) \lambda z}{(1 - \alpha(1 - \lambda))(1 - \lambda)}. \quad (\text{A2})$$

Eliminating $\frac{p_A}{p_B}$ from (A1) and (A2) and rearranging yields:

$$(1 - \alpha\lambda)^\alpha \lambda z^\alpha = (1 - \alpha(1 - \lambda))^\alpha (1 - \lambda),$$

or, in logs:

$$\alpha \ln(1 - \alpha\lambda) + \ln(\lambda) - \alpha \ln(1 - \alpha(1 - \lambda)) - \ln(1 - \lambda) + \alpha \ln(z) = 0 \quad (\text{A3})$$

Let $F(\lambda)$ denote the left-hand side of (A3), and note that:

$$F'(\lambda) = G(1, \lambda) - G(\alpha, \lambda),$$

where the function G is defined as:

$$G(a, \lambda) \equiv \frac{a^2}{1 - a(1 - \lambda)} + \frac{a^2}{1 - a\lambda}.$$

Since $\partial G(a, \lambda) / \partial a > 0$ for all $(a, \lambda) \in (0, 1)^2$, therefore:

$$F'(\lambda) > 0 \text{ for all } \lambda \in (0, 1). \quad (\text{A4})$$

It follows from (A3), (A4) and the implicit function theorem that the equilibrium value of λ_A is given by a function $\lambda(z, \alpha)$ that is strictly decreasing in z , and whose range lies in $(0, 1)$. By symmetry, $\lambda_B = \lambda(1/z, \alpha)$, and since $\lambda_A + \lambda_B = 1$:

$$\lambda(1, \alpha) = 1/2. \quad (\text{A5})$$

Thus according to (4), the profit function is:

$$\phi(z, \alpha) = \frac{\lambda(z, \alpha)(1 - \alpha)}{1 - \alpha\lambda(z, \alpha)}. \quad (\text{A6})$$

Part (a) of the Proposition follows from (A6) and the fact that $\lambda(\cdot)$ is strictly decreasing in z .

It follows directly from (A3) that $\lambda(z, 0) = 1/2$. Part (b) follows from this and (A6).

To show part (c), suppose wlog that $z < 1$, so that $\lambda > 1/2$. Then from (A5) and (A6):

$$\phi(z, \alpha) + \phi(1/z, \alpha) - 2\phi(1, \alpha) = (1 - \alpha)(H(\lambda) - H(1/2)),$$

where the function $H(\cdot)$ is defined as:

$$H(\lambda) = \frac{\lambda}{1 - \alpha\lambda} + \frac{1 - \lambda}{1 - \alpha(1 - \lambda)}.$$

Part (c) follows from the fact that $H'(\lambda) = \left(\frac{1}{1 - \alpha\lambda}\right)^2 - \left(\frac{1}{1 - \alpha(1 - \lambda)}\right)^2 > 0$ when $\lambda > 1/2$.||

Next, we demonstrate results (6) \sim (9). Result (6) follows from routine analysis of Bertrand competition with homogeneous products. It follows from (A3) that

$$\lambda(0, \alpha) = 1 \text{ and } \lim_{z \rightarrow \infty} \lambda(z, \alpha) = 0.$$

Result (7) follows from this and (A6). Result (8) follows from (A5) and (A6). Result (9) follows from direct differentiation of (A3) and (A6), using (A5).||

Next, we derive the Taylor-series approximations (28) \sim (30) to the value functions for the case $\alpha < 1$. Taking into account that a firm with lead n has a profit $\phi(\gamma^{-n}, \alpha)$, and recalling that $\gamma = 1 + \varepsilon$, we have the following first-order approximations to the profit flows:

$$\pi_0 = \phi(1, \alpha), \tag{A7}$$

$$\pi_n = \phi(1, \alpha) - n[\partial\phi(1, \alpha)/\partial z]\varepsilon + O(\varepsilon^2) \tag{A8}$$

and

$$\bar{\pi}_n = \phi(1, \alpha) + n[\partial\phi(1, \alpha)/\partial z]\varepsilon + O(\varepsilon^2). \tag{A9}$$

The Bellman equations (10) \sim (12) can be written, using the policy functions (13) \sim (15), as:

$$\beta r V_0 = \beta \pi_0 + (V_1 - V_0)^2/2 + (\bar{V}_1 - V_0)(V_1 - V_0), \tag{A10}$$

$$\beta r V_n = \beta \pi_n + (V_{n+1} - V_n)^2/2 + (V_0 - V_n)(V_0 - \bar{V}_n) + \beta h(V_0 - V_n) \quad (\text{A11})$$

and

$$\beta r \bar{V}_n = \beta \bar{\pi}_n + (V_0 - \bar{V}_n)^2/2 + (\bar{V}_{n+1} - \bar{V}_n)(V_{n+1} - V_n) + \beta h(V_0 - \bar{V}_n). \quad (\text{A12})$$

Equations (28) ~ (30) follow from replacing the profit flows in (A10) ~ (A12) by their first-order approximations (A7) ~ (A9), and using the method of undetermined coefficients.

To derive the Taylor-series approximations (39) ~ (41) to the value functions for the case $\alpha = 1$, first note that in this case equation (6) implies that the profit flows can be approximated by:

$$\pi_0 = O(\varepsilon^2), \quad \bar{\pi}_n = O(\varepsilon^2)$$

and

$$\pi_n = n\varepsilon + O(\varepsilon^2).$$

Then use these approximations to replace the profit flows in (A10) ~ (A12) and again use the method of undetermined coefficients.||

Next, we derive the approximation (33) to the probability of a neck-and-neck state when γ is small. In view of the approximations (35) ~ (37) for effort, equations (16), (18) and (19) for the steady-state probabilities μ_n can be approximated by:

$$\begin{aligned} \sum_{n=0}^{\infty} \hat{\mu}_n &= 1, \\ \hat{\mu}_1 (2\eta + \theta) &= 2\hat{\mu}_0\eta, \\ \hat{\mu}_2 (3\eta + \theta) &= \hat{\mu}_1\eta, \\ \hat{\mu}_3 (4\eta + \theta) &= \hat{\mu}_2\eta, \\ &\dots \end{aligned}$$

where $\theta = h/\varepsilon$. The latter equations can be solved recursively for $\hat{\mu}_1, \hat{\mu}_2, \hat{\mu}_3, \dots$ in terms of $\hat{\mu}_0$. Doing so yields:

$$1 = \sum_{n=0}^{\infty} \hat{\mu}_n$$

$$= \left(\frac{1}{2} + \frac{\eta}{2\eta + \theta} + \frac{\eta}{2\eta + \theta} \frac{\eta}{3\eta + \theta} + \frac{\eta}{2\eta + \theta} \frac{\eta}{3\eta + \theta} \frac{\eta}{4\eta + \theta} + \dots \right) 2\hat{\mu}_0,$$

which can be rewritten as (33), where:

$$f(\zeta) = \frac{1}{(2+\zeta)} + \frac{1}{(2+\zeta)(3+\zeta)} + \frac{1}{(2+\zeta)(3+\zeta)(4+\zeta)} + \dots > 0. \quad (\text{A13})$$

We then have:

$$\begin{aligned} f'(\zeta) &= -\frac{1}{(2+\zeta)^2} - \frac{1}{(2+\zeta)^2(3+\zeta)} - \frac{1}{(2+\zeta)^2(3+\zeta)(4+\zeta)} - \dots \\ &\quad - \frac{1}{(2+\zeta)(3+\zeta)^2} - \frac{1}{(2+\zeta)(3+\zeta)^2(4+\zeta)} - \dots \\ &\quad - \frac{1}{(2+\zeta)(3+\zeta)(4+\zeta)^2} - \dots \\ &\quad \dots \\ &< 0. \end{aligned}$$

That is:

$$\begin{aligned} f'(\zeta) &= -\frac{f(\zeta)}{(2+\zeta)} - \frac{f(\zeta+1)}{(2+\zeta)(3+\zeta)} - \frac{f(\zeta+2)}{(2+\zeta)(3+\zeta)(4+\zeta)} - \dots \\ &> -f(\zeta) \left(\frac{1}{(2+\zeta)} + \frac{1}{(2+\zeta)(3+\zeta)} + \frac{1}{(2+\zeta)(3+\zeta)(4+\zeta)} + \dots \right) \\ &= -f(\zeta)^2. \end{aligned}$$

Therefore:

$$0 \geq \frac{\zeta f'(\zeta)}{f(\zeta)} \geq -\zeta f(\zeta). \quad (\text{A14})$$

From (A13):

$$0 < f(\zeta) < \frac{1}{2} + \frac{1}{(2+\zeta)} + \frac{1}{(2+\zeta)^2} + \frac{1}{(2+\zeta)^3} + \dots = \frac{1}{1+\zeta}.$$

Therefore:

$$0 \leq \zeta f(\zeta) \leq \frac{\zeta}{1+\zeta} < 1; \quad (\text{A15})$$

From (A14) and (A15):

$$0 \geq \frac{\zeta f'(\zeta)}{f(\zeta)} > -1. \parallel$$

Next, we establish that if $\alpha > 0$ and $h > 0$ then $g > 0$, as promised in footnote 20. In this case, $\mu_0 > 0$, for otherwise equations (18) and (19) would

imply that $\mu_n = 0$ for all $n > 0$, contradicting (16). So according to (G) we need only show that $x_0 > 0$. To do this suppose on the contrary that $x_0 = 0$. Then by (10) and (13):

$$rV_1 \geq \pi_1 + (\bar{x}_1 + h)(V_0 - V_1), \quad (\text{A16})$$

whereas by (12) and Proposition 1(a):

$$rV_0 = \pi_0 < \pi_1. \quad (\text{A17})$$

From (A16) and (A17) $V_1 > V_0$, which together with (15) implies $x_0 > 0$.||

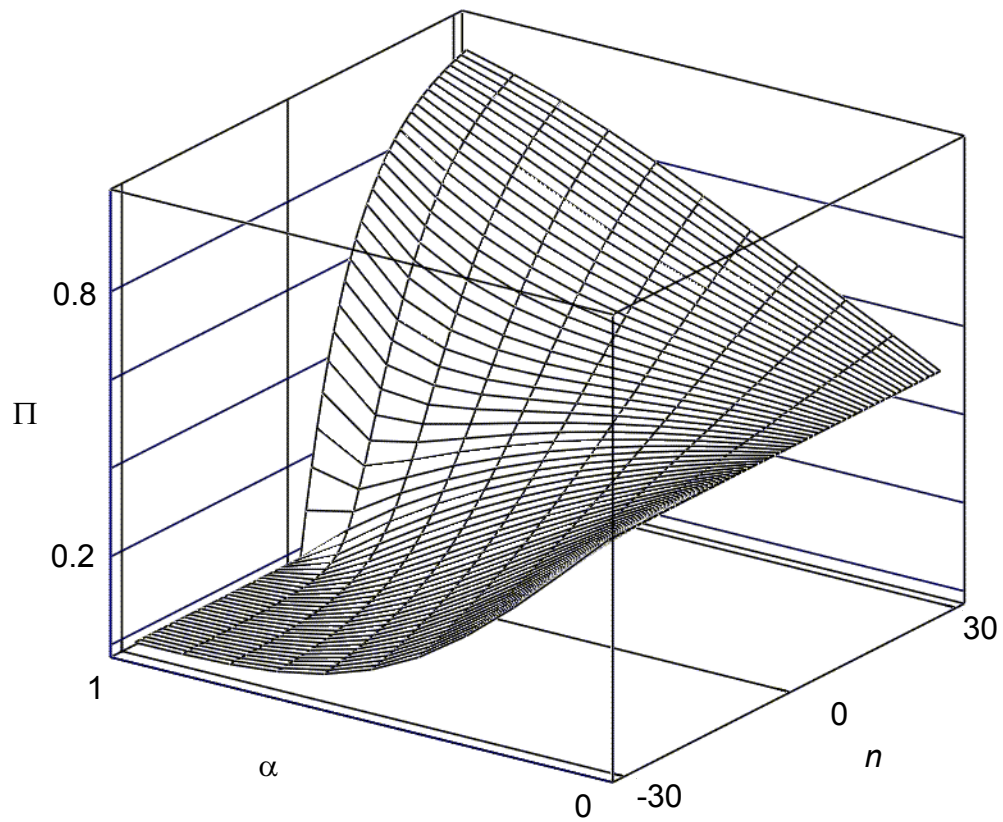

Profit

FIGURE 1. A firm's profit Π as a function of its technological lead n and the degree of competition α when $\gamma = 1.135$.

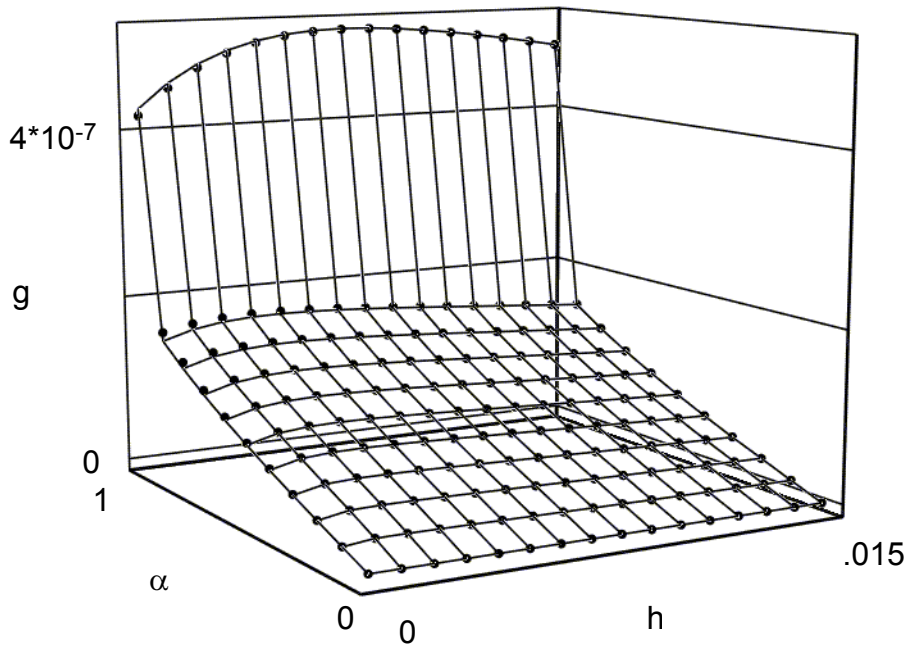

FIGURE 2. The dots depict the two expansions for growth, as a function of the degree of competition α and the propensity to imitate h , when $\gamma = 1.0001$. Direct calculation (depicted by the wireframe) shows that the approximations are almost exact in this case.

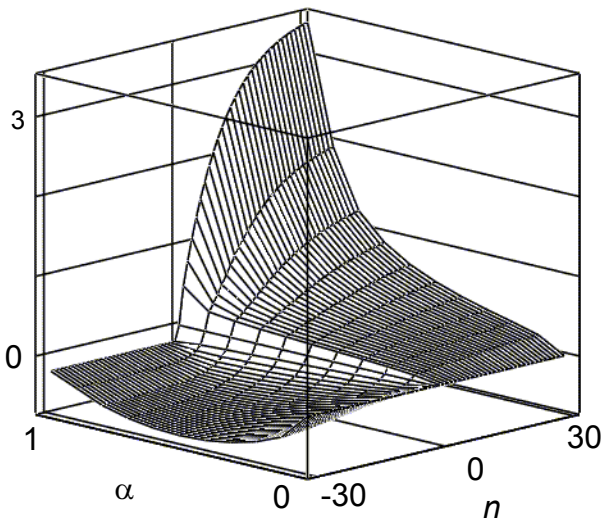

Fig3(a)

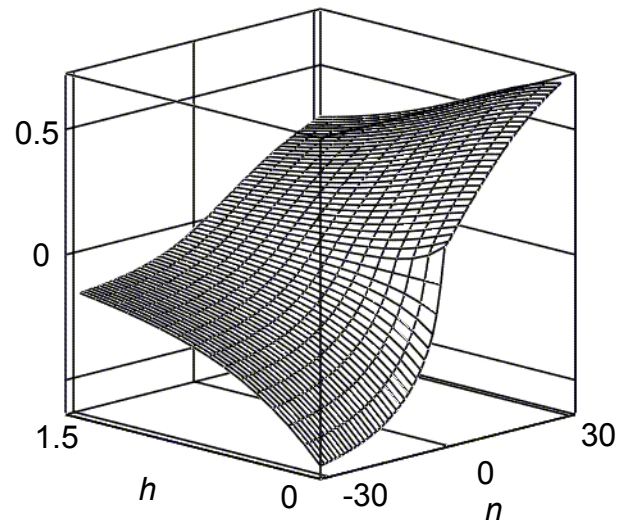

Fig3(b)

FIGURE 3. A firm's value minus its neck-and-neck value, as a function of its technological lead n , when $\gamma = 1.135$. In panel (a) the propensity to imitate h is fixed at 0. In panel (b) the degree of competition α is fixed at 0.5.

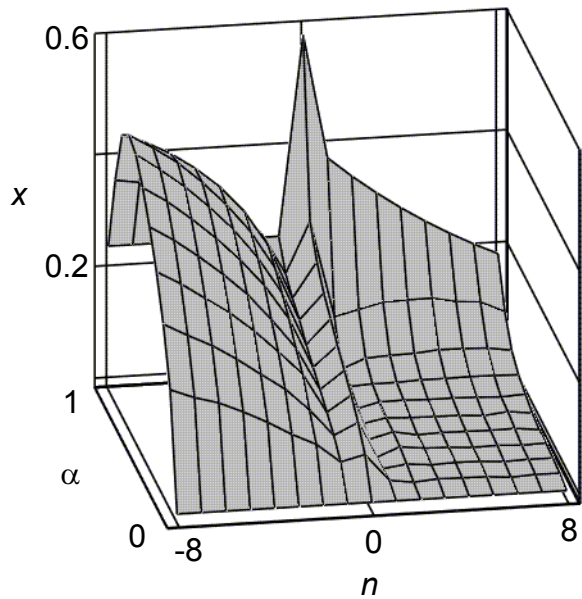

Fig4(a)

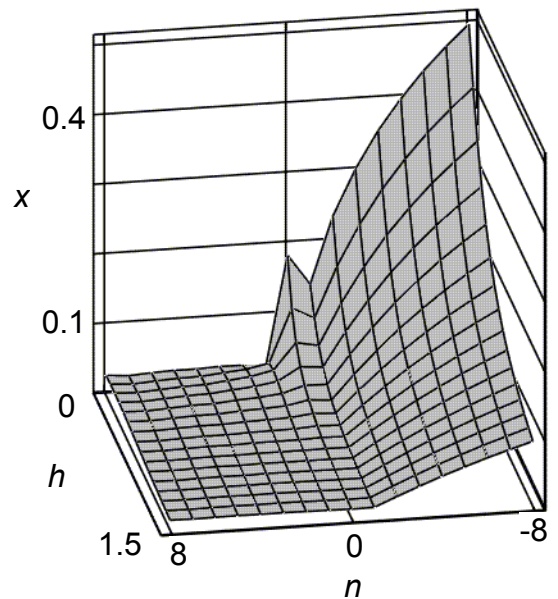

Fig4(b)

FIGURE 4. A firm's R&D effort x as a function of its technological lead n when $\gamma = 1.135$. In panel (a) the propensity to imitate h is fixed at 0. In panel (b) the degree of competition α is fixed at 0.5.

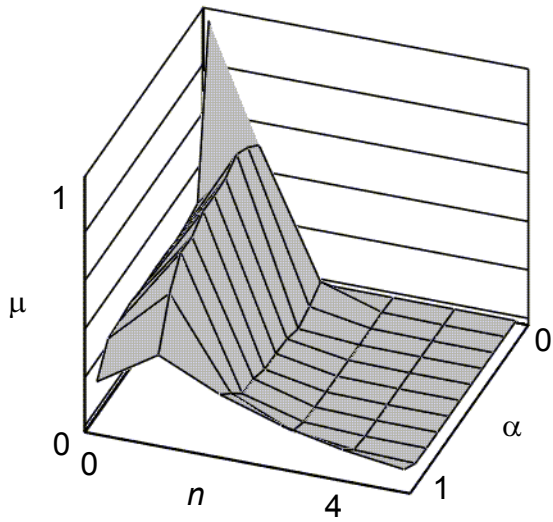

Fig5(a)

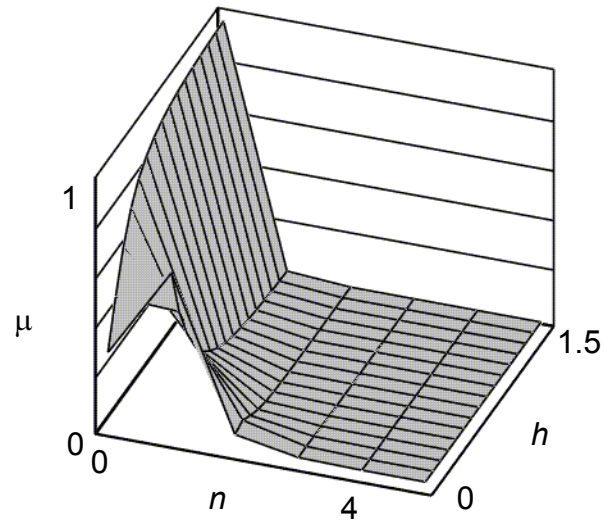

Fig5(b)

FIGURE 5. The steady-state distribution of technological leads n , when $\gamma = 1.135$. In panel (a) the propensity to imitate h is fixed at 0. In panel (b) the degree of competition α is fixed at 0.5.

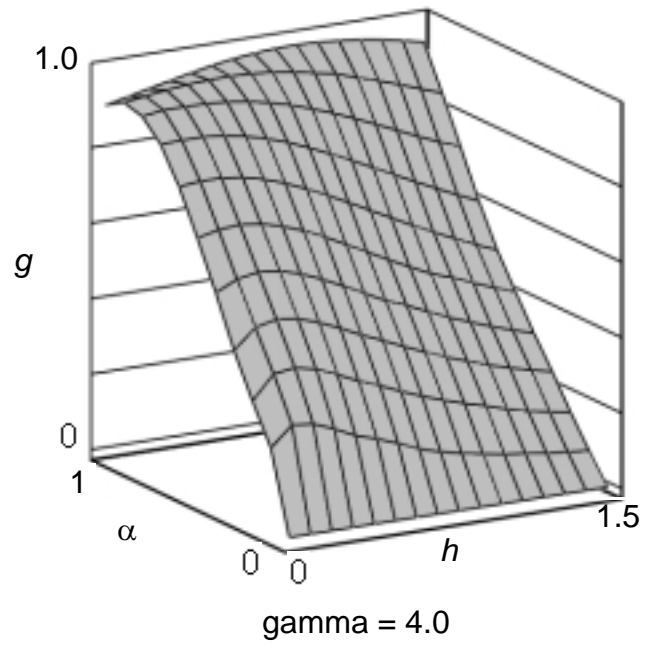
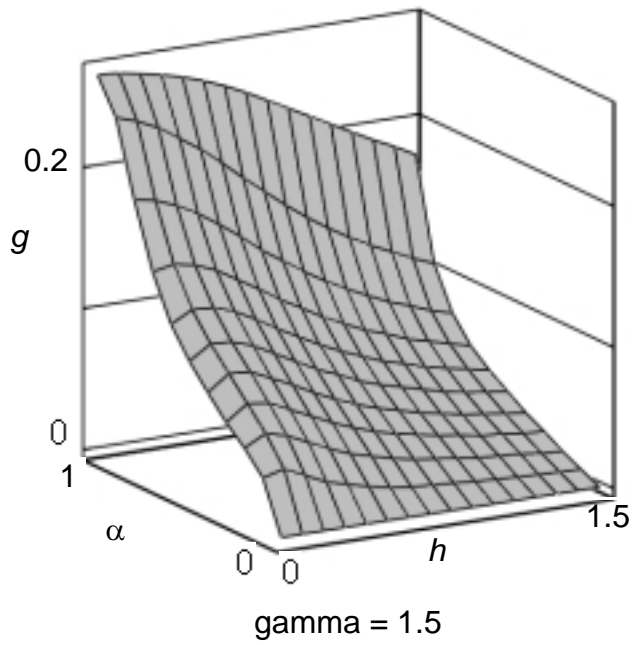
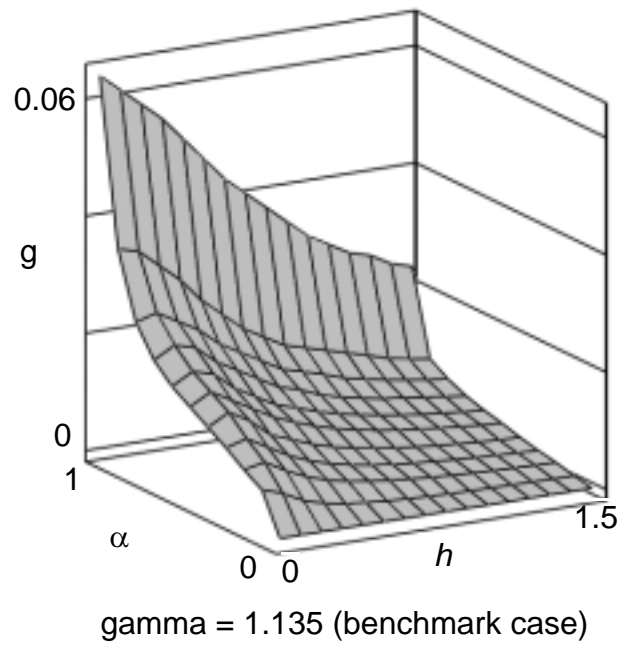
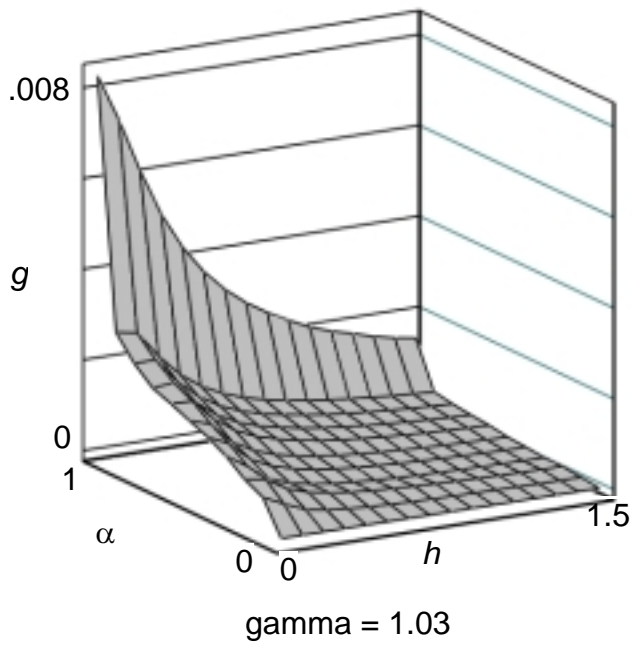

FIGURE 6. Growth as a function of the degree of competition α and the propensity to imitate h .